

## MD ISOLATORS

Replaces RAB isolators

### DESCRIPTION

The advantage of this mount is that it is a high-damping elastic compound. Its special mix affords it a high degree of anti vibration isolation and offers great stability to suspended equipment.

### TECHNICAL CHARACTERISTICS

- Metal hood that protects the part from possible oil splashes.
- It has an electrolytic coating that protects the part from corrosion.
- They have an interlocking metal component that provides a fail-safe protection for mobile applications. This device limits the ascending vertical movement when the mounting is submitted to shocks at traction.



### APPLICATIONS

This mount has been specially designed to insulate engines that produce high-amplitude vibrations. Engines from 1 to 3 cylinders, Motor Pumps, Gensets, Compressors, Ventilators

### WHEN IS IT USED?

The MD-type works as an anti vibration mount but also as an engine stabiliser. This mount is used when conventional rubber metal mounts do not offer sufficient stability to the suspended equipment.

The MD is installed in small engines of 1, 2 and 3 cylinders which are particularly unstable.

These mounts are suitable for the suspension of machines which are started and stopped a lot and where the passage of resonance needs a high degree of damping or work in conditions which are close to the frequency of resonance of the system.

Diesel engines require MD mounts, particularly when they have few large-diameter cylinders, which makes the engine create high-amplitude vibrations, therefore requiring extra damping to correct these high amplitudes.

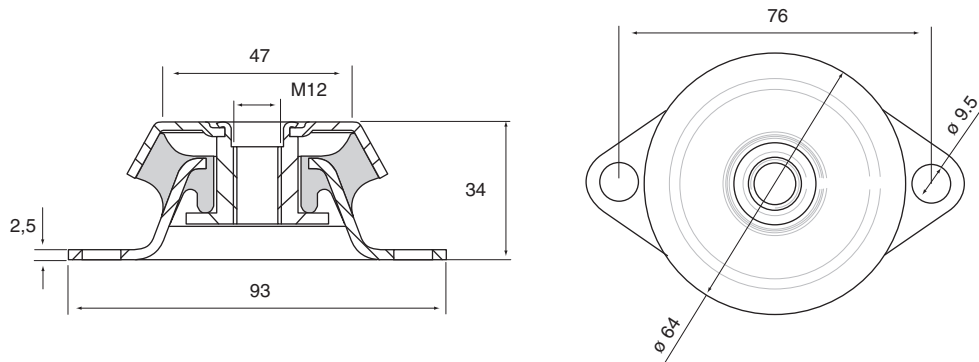

Part No.	Load Kg	Deflection mm	Weight Kg
M135210	130	3.5	0.23
M135212	105	3.5	0.23
M135213	70	3.5	0.23
M135219	50	3.0	0.23