



Mackay Marine



Mackay Hull Isolation Mounts

Provide a bearing medium between vessels' superstructure and the hull. Vessels utilizing Mackay Hull Isolators are operating worldwide in various conditions and applications including high-speed passenger ferries and pilot boats.

Features

Hull Isolators Mounts are designed to support and isolate the superstructure, or living area sections in thee compression mode whilst allowing horizontal, lateral and rotational hull movements by virtue of the shear capacity of the mounts.





The design of the end-plates provides two options of mounting arrangements. The first option enables a complete bolted arrangement (**HD Series**) and the other option is bolted arrangement on one end plate and welding arrangement on the other end plate (**HDA Series**).

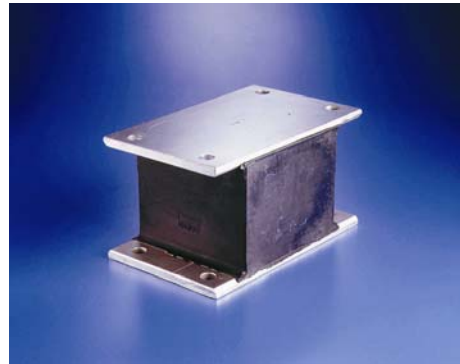
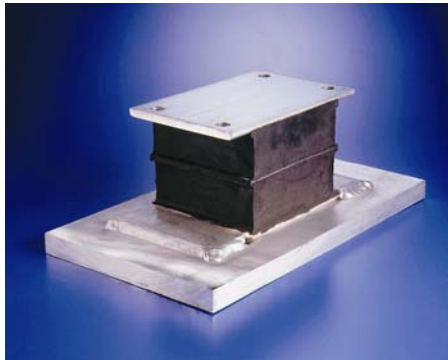

The aluminium plates are 5083/H321. Combinations of end plate materials are available if required. Mackay has manufactured combination aluminium / steel arrangements for aluminium superstructure / steel hull combinations.

A wide range of available rubber properties results in a wide range of vertical loads from the same space envelope.

Marine Classification Societies Certifications

Mackay Hull Isolation Mounts have been tested and/or certified by the following Marine Classification Societies for use on their appropriately classified and/or surveyed vessels:

- Det Norkse Veritas (DNV)**
- Lloyd's Register of Shipping (LR)**
- Germanisher Lloyd (GL)**
- American Bureau of Shipping (ABS)**
- U.S. Coast Guards (USCG)**
- Dept. of Transport, Queensland (D.O.T.)**



Mackay Marine

Mackay Superstructure Isolators (Hull Isolators) are found on most of the world's resiliently mounted superstructure aluminium Fast Ferries. Mackay also supplies resilient superstructure flexible joint for weather sealing of resiliently mounted superstructures.

Mackay has supplied Superstructure Isolators to many shipyards including:

- Incat Tasmania (Australia)
- Austal Ships (Australia)
- NQEA (Australia)
- Northwest Bay Ships (Australia)
- Nichol Brothers (USA)
- Gladding Hearn (USA)
- Derecktor Shipyards (USA)
- Aluminium Shipbuilding (UK)
- VT Halmatic (UK)
- Bazan (Spain)
- Arvandan Shipbuilding (Iran)

Superstructure isolators have also been used for workboats for isolation of wheel-houses and crew cabins to increase crew comfort.

Mackay also manufactures and supplies a range of stainless steel and marine grade aluminium flexible isolators for mounting ancillary equipment in wet areas.





Mackay Marine

HULL ISOLATION MOUNTS

HD SERIES – Bolted Fitment

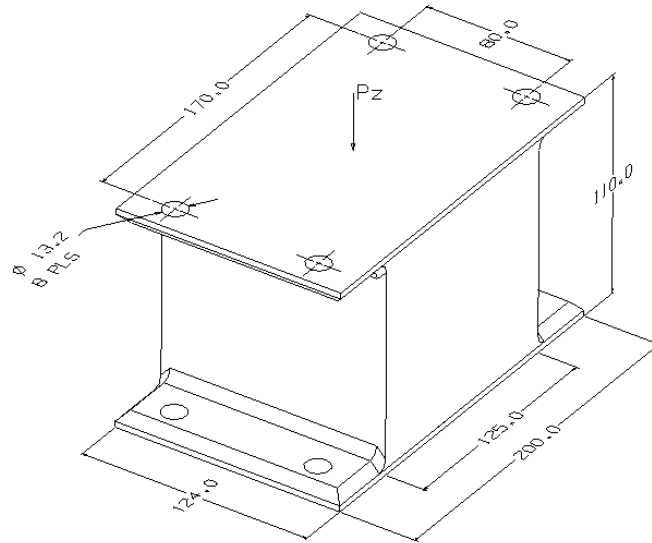

HD1P SERIES – Bolted Fitment

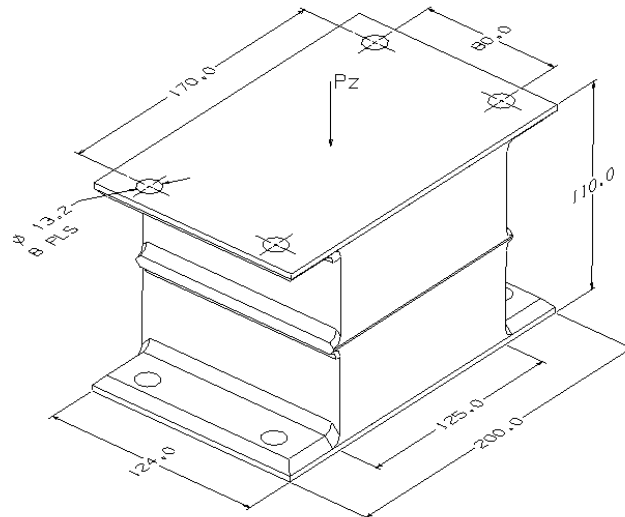



Mackay Marine

Compression Loads - HD Series

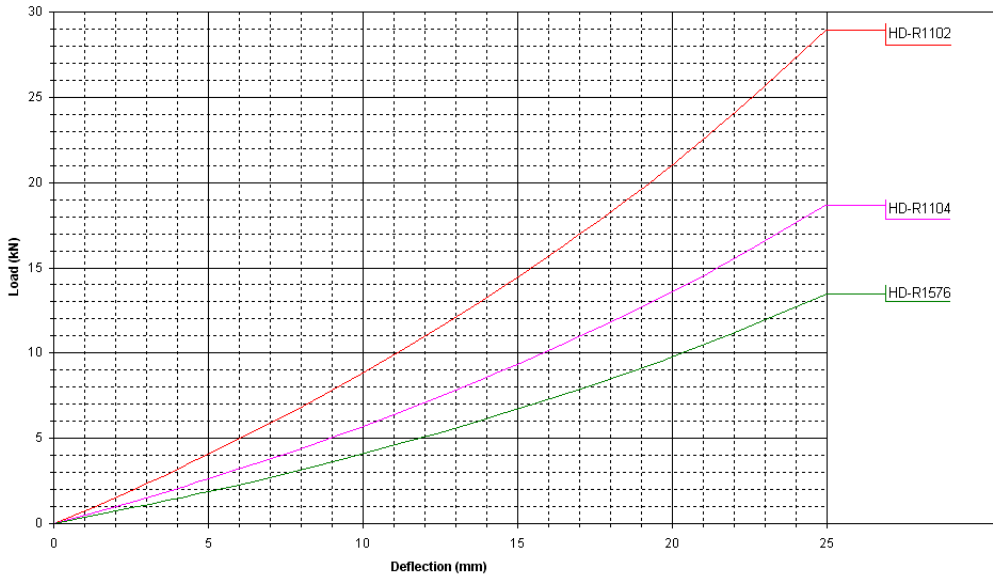

Shear Loads - HD Series
(At Fixed PreCompression Load to achieve 12mm Nominal Deflection)

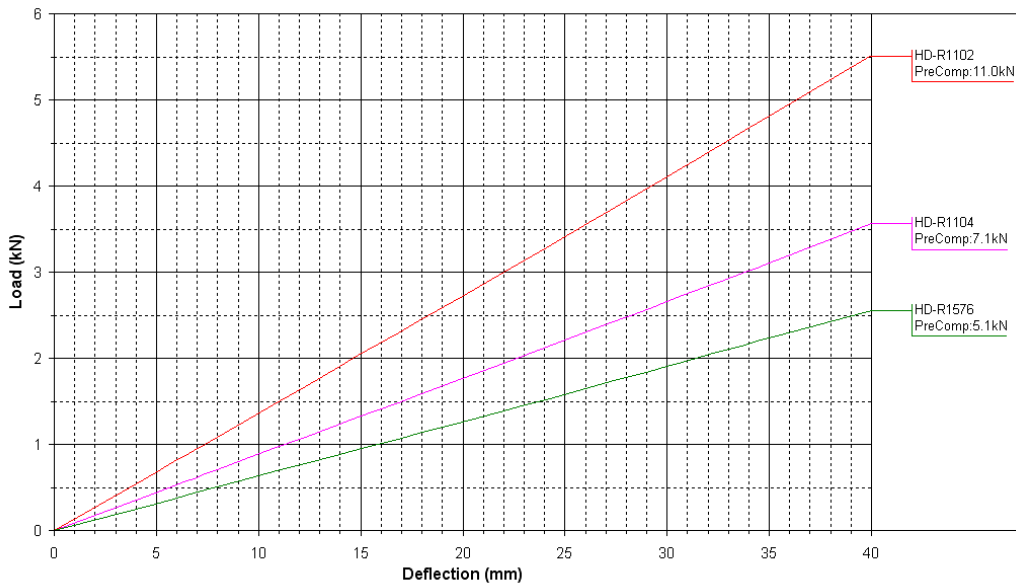



Part Number	Vertical Load, P_z , kN	Vertical Deflection, d_z , mm
HD-R1576 HDA-R1576	5	12
HD-R1104 HDA-R1104	7	12
HD-R1102 HDA-R1102	11	12

Parts listed are a selection of a wider range, details of which are available on request.

Hull Isolation Mounts should not be used at both maximum vertical load capacity and maximum shear deflection. Hence, the multiple of P_z (vertical load) and d_x (shear deflection) should be less than the value quoted in the table.

Mackay Consolidated Industries operate a policy of continuous improvement and development. We reserve the right to change design and specification of our products without prior notification or alteration of literature. We will not be held responsible for any danger or damage incurred through improper use or installation.





Mackay Marine

HULL ISOLATION MOUNTS

HDA SERIES – Bolted & Welded Fitment

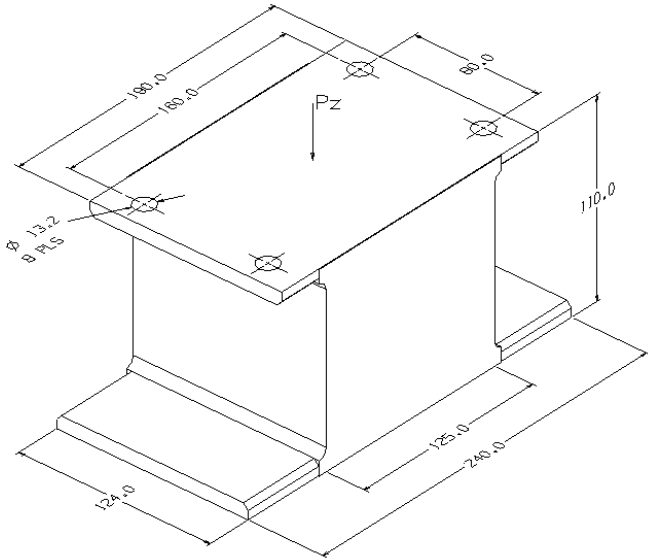

HDA1P SERIES – Bolted & Welded Fitment

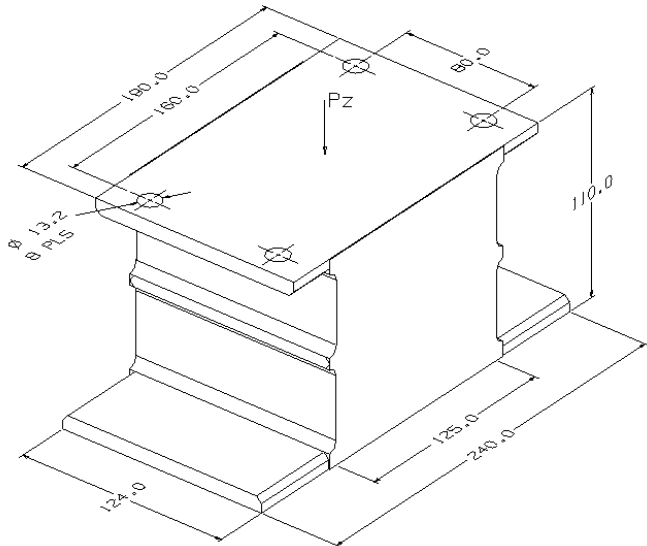



Mackay Marine

Compression Loads - HD1P Series

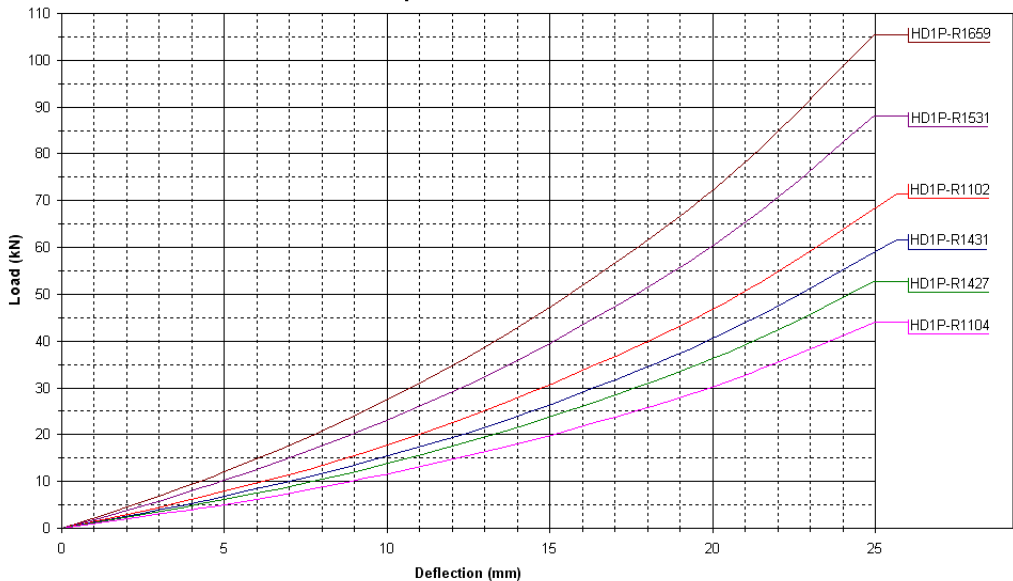

Shear Loads - HD1P Series

(At Fixed PreCompression Load to achieve 12mm Nominal Deflection)

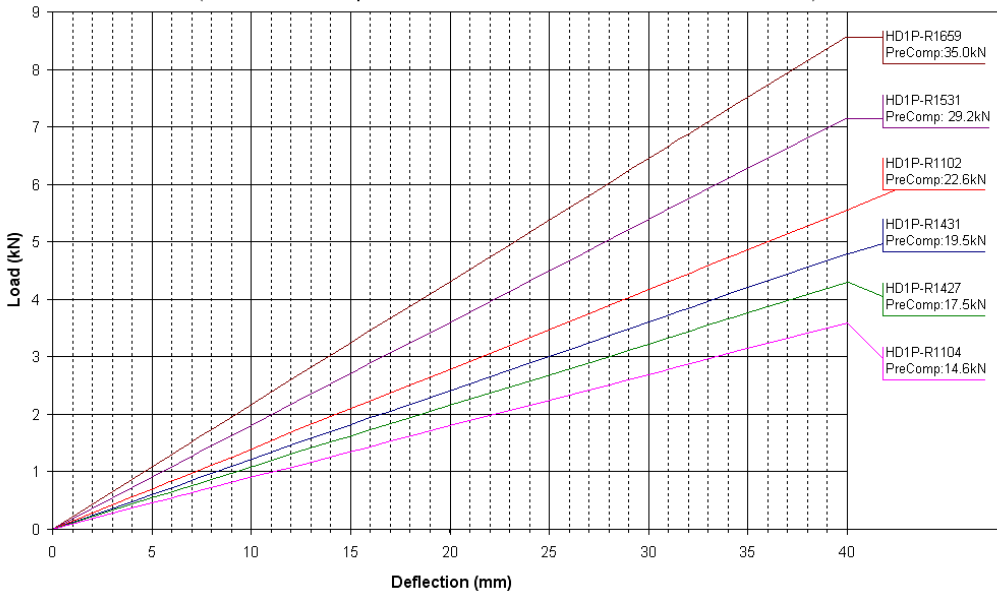



Part Number	Vertical Load, P_z , kN	Vertical Deflection, d_z , mm
HD1P-R1104 HDA1P-R1104	15	12
HD1P-R1472 HDA1P-R1472	17	12
HD1P-R1431 HDA1P-R1431	20	12
HD1P-R1102 HDA1P-R1102	23	12
HD1P-R1531 HDA1P-R1531	29	12
HD1P-R1659 HDA1P-R1659	35	12

Parts listed are a selection of a wider range, details of which are available on request.

Hull Isolation Mounts should not be used at both maximum vertical load capacity and maximum shear deflection. Hence, the multiple of P_z (vertical load) and d_x (shear deflection) should be less than the value quoted in the table.

Mackay Consolidated Industries operate a policy of continuous improvement and development. We reserve the right to change design and specification of our products without prior notification or alteration of literature. Mackay will not be held responsible for any danger or damage incurred through improper use or installation.

